

Application Guideline

Comic Category

[Theme]

An original comic using Hokkaido as a material (comics appeared in doujinshi/fanzines are eligible, but parody comics are not acceptable.)

(e.g.) A comic that enhances the charm of Hokkaido with a theme of Hokkaido's history, culture, sports, nature, food, etc.

* Both story comics and four-frame comic strips are eligible.

* Before using expressions regarding specific countries, ethnic groups or cultures, conduct an adequate investigation to understand them well, and express them carefully.

[Applicant Eligibility]

Anybody (Multiple works can be submitted. Co-produce comics are acceptable.)

[Submitting Rules]

-Around 16 to 32 page for story comics

-Around 3 to 5 pages for four-frame comic strips(2 works on 1 page)

-The words must be in Japanese or English. (Add Japanese translation for English as much as possible.)

-The work can be color, monochrome or mixed, but the selection will be done with monochrome.

-The title page (cover) must be on the left when bound on the right.

-Add page number at bottom center.

<For Digital Manuscripts>

-If it is in color, the data must be in jpeg format. (Resolution: 350dpi (original size))

-If it is in monochrome, the data must be in binarized jpeg format. (Resolution: 600dpi or 1,200 dpi (original size))

<For Hand Drawn Manuscripts>

-It has to be a two-dimensional piece on B4 comic manuscript paper or a hand drawn manuscript on Kent paper. (Photocopied manuscripts are not acceptable)

-Works drawn on both sides of paper are not acceptable.

-Works must be drawn with ink or drawing ink. (They need to be clearly photocopied.)

-The title and words must be written clearly with a thick pencil.

Manuscript Size

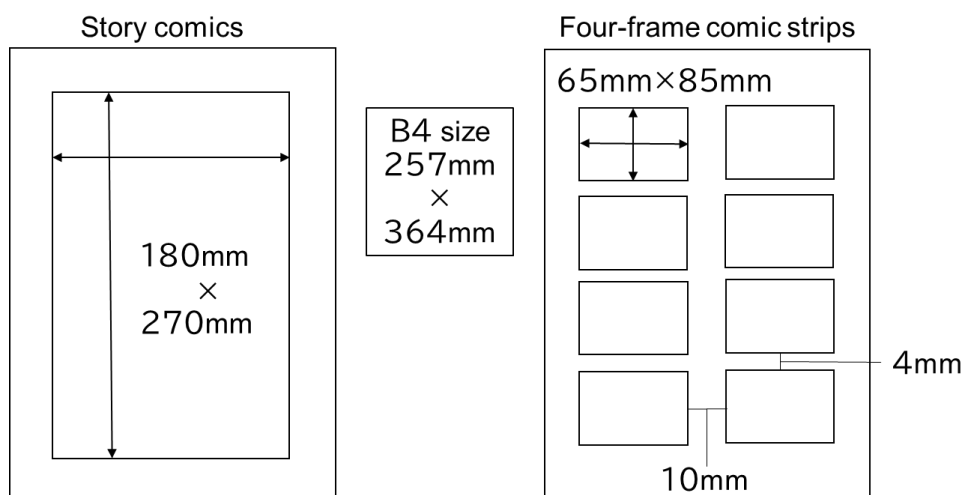

Application Guideline

Illustration Category

[Theme]

An illustration with a theme of “ECO”.

“ECO” is the adjective which describes the state of being environmentally conscious. ¹

We are facing numerous environmental issues today, including global warming, pollution, and weakening biodiversity. Yet, our actions can still change the course of the future: for instance, we may work on promotion of carbon neutrality and renewable energy, energy saving, recycling, and conservation of natural environment. We are looking forward to seeing your piece of work on “ECO,” which inspire us to take actions against environmental issues.

¹ “Eco” is the Japanese equivalent of the word “eco-friendly” in English.

* Before using expressions regarding specific countries, ethnic groups or cultures, conduct an adequate investigation to understand them well, and express them carefully.

< Image of the work >

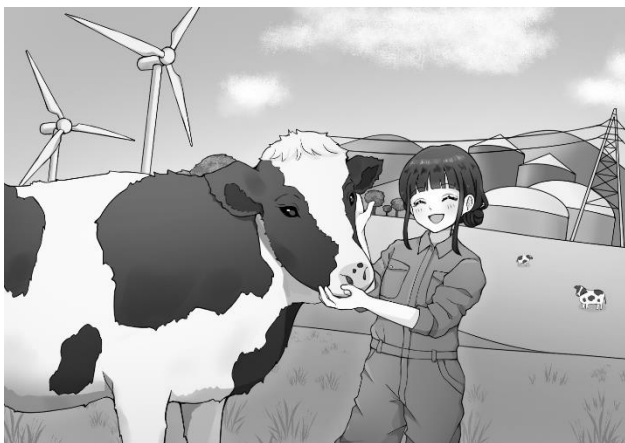

[Applicant Eligibility]

Anybody (Multiple works can be submitted. Co-produce comics are acceptable.)

[Submitting Rules]

A work on a sheet of A4 or B4 paper. Any paper can be used and any painting material but oils can be used, and the work can be either in color or monochrome.

3D works including cutout pictures and paste pictures are not acceptable.

<For Digital Works>

-If it is in color, the data must be in jpeg format. (Resolution: 350dpi (original size))

-If it is in monochrome, the data must be in binarized jpeg format. (Resolution: 600dpi or 1,200 dpi (original size))

How to Submit (Both Categories)

[Submitting Documents, etc.]

- Submit a digital or hand drawn manuscript together with the application form for Kita no Manga Taisho. (Submit an application form for each work when you submit multiple works.)
- For digital data, submit a CD-R or a DVD-R together with a printed copy. (Make sure to use B4 paper for comics.)
- Do not fold hand drawn manuscripts. (Photocopied manuscripts are not acceptable.)
- If you use a pen name, announcement of the result will be done with your pen name.
- Award-winning works of the Comic Category, all submitted works of the Illustration Category and all works submitted from overseas shall not be returned.

[Close Date]

Monday, October 16th 2023 (postmark deadline)

[Awards]

Comic Category

- Hokkaido Prefecture Governor's Award (1 work): a certificate and ¥100,000
- Sapporo City Mayor's Award (1 work): a certificate and ¥50,000
- Special Award (3 works): a certificate and ¥30,000
- U-15 Hokkaido Prefecture Governor's Award (1 work): a certificate and a bookstore gift certificate of ¥15,000
- U-15 Sapporo City Mayor's Award (1 work): a certificate and a bookstore gift certificate of ¥9,000
- U-15 Special Award (2 works): a certificate and a bookstore gift certificate of ¥5,000

Illustration Category

- Hokkaido Prefecture Governor's Award (1 work): a certificate and ¥50,000
- Sapporo City Mayor's Award (1 work): a certificate and ¥30,000
- Special Award (3 works): a certificate and ¥10,000
- U-15 Hokkaido Prefecture Governor's Award (1 work): a certificate and a bookstore gift certificate of ¥7,000
- U-15 Sapporo City Mayor's Award (1 work): a certificate and a bookstore gift certificate of ¥5,000
- U-15 Special Award (2 works): a certificate and a bookstore gift certificate of ¥3,000

* There will be more awards of medals, a painting software and Hokkaido food, etc. from supporting companies

[Results Announcement]

Around January 2024 (planned)

Announcement will be made on Hokkaido Government website, etc.

[Delivery Address, Contact Information]

[Kita no Manga Taisho Office]

Culture Promotion Section, Culture Promotion Division, Bureau of Cultural Affairs, Department of Environment and Lifestyle, Hokkaido Government

Kita 3-jo Nishi 6-chome, Chuo-ku, Sapporo, Hokkaido, Japan 060-8588

Phone: 011-231-4111 (Extension 24-407)

Email: kansei.bunka@pref.hokkaido.lg.jp

8th Kita no Manga Taisho Application Form

【Notice】Minors require parental consent to apply.

*Office use only

受付番号:

受付年月日: 令和5年 月 日

Category

Comic Category

Illustration Category

Production Process

Hand drawn

Digital

Work

Title

Number of pages (including the cover)

*Only for Comic Category

Applicant

Name

Pen Name

Address

Contact Information

Phone Number

FAX Number

E-mail

Birth Date

DD /MM /YYYY

(Age:) *As of January 1, 2024

Occupation or Name of School

How did you learn about Kita no Manga Taisho?

I submit this work after understanding and agreeing the application requirements and the Notes for Application.

DD / MM

2023

Signature

Fill in the following fields only when applying for Comic Category.

Returning of the work

Do you want your work to be returned after the selection?

Yes No

*Enclose an envelope with necessary stamps if you want your work returned. (Your work will be discarded if you don't want it returned.)

*Award-winning works of the Comic Category, all submitted works of the Illustration Category and all works submitted from overseas shall not be returned.

Provision of your information to comic magazine publishers

If comic magazine publishers related to the selection want the information of your work or yourself, do you agree that your information is shared to them?

Yes No

Comments from judges

If there are comments from judges including comic artists and publishers of comic magazines, do you want us to let you know the comments?

*We will let you know the comments as they are made including harsh ones.

Yes No

Notes for Application

- Works that don't meet the eligibility or rules are considered not applicable for the selection.
- When it is found that the work has won in other contests or has been printed in commercial magazines, the work will be excluded from the selection process and the awards may be cancelled even after the winners have been decided.
- The work shall not infringe the third person's copyright or portrait right. For any work that infringes those rights or that might do so, the awards may be cancelled even after the winners have been decided.
- If there is a claim by a third party regarding portrait right or copy right including plagiarism and illegal copying, any responsibility shall be compensated by the applicant/creator.
- Copyright (including Article 27 and 28 of the Copyright Act) and any other rights of all submitted works in Illustration Category and all winning works in Comic Category belong to the Government of Hokkaido. Thus the Government of Hokkaido shall be able to use all works in Illustration Category and all or parts of winning works in Comic Category in the following ways:
 - *On the internet or other electronic media
 - *On publications issued by the Government of Hokkaido (including ones issued by contractors)
 - *In exhibitions etc. held by the Government of Hokkaido
 - *In exhibitions and on printed matters approved by the Government of Hokkaido
- Creators of the works of Illustration Category and winning works of Comic Category shall not exercise any moral rights against the Government of Hokkaido or other third persons designated by the Government of Hokkaido.
- Works that didn't win in Comic Category shall be returned to the creators according to their wishes using the envelopes enclosed by the creators. If an envelope with necessary stamps is not enclosed, the work will be sent by cash-by-delivery. (Award-winning works of the Comic Category, all submitted works of the Illustration Category and all works submitted from overseas shall not be returned.)
- The Government of Hokkaido is not responsible for any accident during transportation. Personal information collected while submission of the works shall not be used for purposes other than this contest and the following.
- If the creator agrees, information of the work and creator will be shared to comic magazine publishers upon their requests. The works are subject to alteration as necessary upon being published. The creators may be asked for cooperation in touching up and modifying their works.