

Application Guideline

Comic Category

[Eligible Works]

Unreleased, original works which feature motifs that represent Hokkaido

However, the following works are not eligible for entry:

- Works that have been commercialized or works that have been produced based on a paid commission
- Fan works based on pre-existing works
 - E.g. Fanart or parodies that use characters, names, settings, and/or stories from existing works
- Works that may infringe on copyright or other rights of third parties
- **Works produced using generative AI**

*** If you intend to include references to specific countries, groups of people or culture in your work, please conduct thorough research and contact experts or related organizations to ensure that your references are appropriate.**

* If you are to include a map of Hokkaido in your work, please be mindful that the Northern Territories are part of Japanese territory.

[Applicant Eligibility]

Anybody (Multiple works can be submitted. Co-produce comics are acceptable.)

[Submitting Rules]

- Around 16 to 32 pages for story comics
- Four panel comic strips should be three to five pages long (two four-panel comic strips per page)
- There are no requirements for the panel layouts of one-page comics
- The words must be in Japanese or English. (Add Japanese translation for English as much as possible.)
- The work can be color, monochrome or mixed, but the selection will be done with monochrome.
- The title page (cover) must be on the left when bound on the right.
- Add page number at bottom center.

*** Use of generative AI is not permitted for any part of the work (story, arrangement, art, etc.)**

<For Digital Manuscripts>

- If it is in color, the data must be in jpeg format. (Resolution: 350dpi (original size))
- If it is in monochrome, the data must be in binarized jpeg format. (Resolution: 600dpi or 1,200 dpi (original size))

<For Hand Drawn Manuscripts>

- It has to be a two-dimensional piece on B4 comic manuscript paper or a hand drawn manuscript on Kent paper. (Photocopied manuscripts are not acceptable)
- Works drawn on both sides of paper are not acceptable.
- Works must be drawn with ink or drawing ink. (They need to be clearly photocopied.)
- The title and words must be written clearly with a thick pencil.

Manuscript Size

Story comics / One-page comic

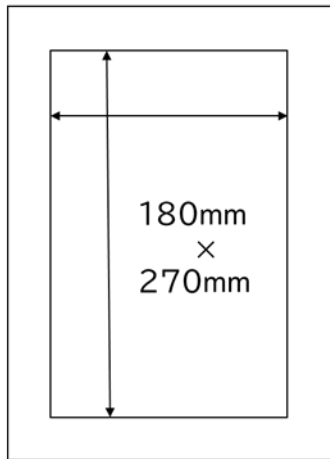

B4 size
257mm
×
364mm

Four-frame comic strips

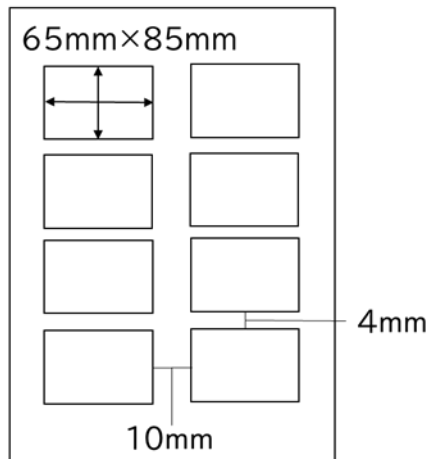

Application Guideline

Illustration Category

[Eligible Works]

Unreleased, original works which feature motifs that represent Hokkaido

However, the following works are not eligible for entry:

- Works that have been commercialized or works that have been produced based on a paid commission
- Fan works based on pre-existing works
 - E.g. Fanart or parodies that use characters, names, settings, and/or stories from existing works
- Works that may infringe on copyright or other rights of third parties
- Works produced using generative AI

*** If you intend to include references to specific countries, groups of people or culture in your work, please conduct thorough research and contact experts or related organizations to ensure that your references are appropriate.**

* If you are to include a map of Hokkaido in your work, please be mindful that the Northern Territories are part of Japanese territory.

[Applicant Eligibility]

Anybody (Multiple works can be submitted. Co-produce comics are acceptable.)

[Submitting Rules]

A work on a sheet of A4 or B4 paper. Any paper can be used and any painting material but oils can be used, and the work can be either in color or monochrome.

3D works including cutout pictures and paste pictures are not acceptable.

* Tracings of photos or photos turned into illustrations are not eligible for entry.

* Entries must not include written titles or slogans.

***Use of generative AI is not permitted for any part of the work (arrangement, art, etc.)**

<For Digital Works>

-If it is in color, the data must be in jpeg format. (Resolution: 350dpi (original size))

-If it is in monochrome, the data must be in binarized jpeg format. (Resolution: 600dpi or 1,200 dpi (original size))

How to Submit (Both Categories)

[Submitting Documents, etc.]

-Submit a digital or hand drawn manuscript together with the application form for Kita no Manga Taisho.

(<https://www.harp.lg.jp/WmLVdST7>)

*Submit an application form for each work when you submit multiple works.

-For digital data, submit a CD-R or a DVD-R together with a printed copy. (Make sure to use B4 paper for comics.)

-Do not fold hand drawn manuscripts. (Photocopied manuscripts are not acceptable.)

-If you use a pen name, announcement of the result will be done with your pen name.

- Award-winning works of the Comic Category, all submitted works of the Illustration Category and all works submitted from overseas shall not be returned.

[Close Date]

Monday, October 26th 2026 (postmark deadline)

[Awards]

Comic Category

- Hokkaido Prefecture Governor's Award (1 work): a certificate and ¥100,000
- Sapporo City Mayor's Award (1 work): a certificate and ¥50,000
- Special Award (3 works): a certificate and ¥30,000
- U-15 Hokkaido Prefecture Governor's Award (1 work): a certificate and a bookstore gift certificate of ¥15,000
- U-15 Sapporo City Mayor's Award (1 work): a certificate and a bookstore gift certificate of ¥9,000
- U-15 Special Award (2 works): a certificate and a bookstore gift certificate of ¥5,000

Illustration Category

- Hokkaido Prefecture Governor's Award (1 work): a certificate and ¥50,000
- Sapporo City Mayor's Award (1 work): a certificate and ¥30,000
- Special Award (3 works): a certificate and ¥10,000
- U-15 Hokkaido Prefecture Governor's Award (1 work): a certificate and a bookstore gift certificate of ¥7,000
- U-15 Sapporo City Mayor's Award (1 work): a certificate and a bookstore gift certificate of ¥5,000
- U-15 Special Award (2 works): a certificate and a bookstore gift certificate of ¥3,000

* There will be more awards of medals, a painting software and Hokkaido food, etc. from supporting companies

[Results Announcement]

Prize winning entries will be announced via the Hokkaido Government website etc. in or around February 2027 (planned announcement date). Entries which pass to the second (final) stage of screening will also be announced as selected entries.

In principle, the results will be announced using the pen names of authors/artists who applied with a pen name. However, if the applicant specifically requests the publication of their real name, we will accommodate this to the extent possible in subsequent announcements of results and other materials.

【Please note】

- Entries that do not meet the entry criteria or follow the format specifications will be excluded from the competition.
- Works found to have been made using generative AI, to have been entered in other competitions, or to have been published in commercial magazines may be disqualified from the selection process. If discovered after selection, they may have their award(s) revoked.
- Submitted works must not infringe on the copyrights, portrait rights, or other rights (hereinafter referred to as “copyrights, etc.”) of any third party.
- Entries that are deemed to infringe or potentially infringe on copyrights, etc. may have their award revoked even after being selected as a winner.
- In case a third party makes a claim regarding plagiarism, illegal copying, or any other copyright-related matter regarding the submitted work, the author shall bear all responsibility.
- If you intend to include references to specific countries, groups of people or culture in your work, please conduct thorough research and contact experts or related organizations to ensure that your references are appropriate.
- If you are to include a map of Hokkaido in your work, please be mindful that the Northern Territories are part of Japanese territory.

- The Hokkaido Government shall not be responsible for any accident which may occur during the delivery of the submitted work.
- The personal information collected during the application process shall not be used for purposes other than this competition.
- Upon the reveal of the winning entries, the organizer may request the creators to retouch some parts of their submitted work if the need arises.

【On handling of the submitted works】

- For the comic category of the competition, the judging process is carried out in cooperation with editors of the sponsoring comic magazines. We will provide the editors with information about the author and the artwork if requested. (As permitted by the author.)
- The organizers may use the entirety or parts of a submitted work free of charge on the occasions listed below, and the author agrees to such use. (Copyright of the submitted work remains with its creator.)
- The winning entries will be widely publicized through exhibitions and websites, and utilized on diverse occasions.
- Entries relating to the subjects below will be considered for use by the organizer in the ways shown in the table.

Subject	Category		Purposes of Use
	Comics	Illustrations	
Community Safety Initiatives		○	<ul style="list-style-type: none"> • Posted on websites and social media • Used in promotional and educational projects by the Hokkaido Prefectural Police, the Hokkaido Board of Education, and other related parties such as municipalities

Eliminate Drunk Driving, Prevent Special Fraud (impersonating a police officer etc.)	○	○	•Used in promotional materials such as posters and leaflets
Celebrating 5 Years Since Its Inscription! The Appeal of the Jomon Prehistoric Sites in Hokkaido and Northern Tohoku		○	•Used in events •Posted on websites •Published in related civil organization's newsletters
Aim for Olympians!	○		•Posted on websites and social media
Hokkaido J-League Soccer Camp		○	•Posted on websites and social media
One Health Hokkaido – The Work of Veterinarians	○	○	•Used at PR events •Posted on websites and social media
Hokkaido's Beautiful Landscapes		○	• Introduced at Landscape Day panel displays •Used in materials related to Landscape Day
Notsuke-Fūren-Nemuro - Future Quasi-National Park		○	•Used in leaflets and websites •Used in original products conducted by the Nemuro General Subprefectural Bureau
Sapporo: Where Snow Meets Art		○	•Used in PR materials for culture and art-related activities

[Delivery Address, Contact Information]

【Kita no Manga Taisho Office】

Culture Promotion Section, Culture Promotion Division, Bureau of Cultural Affairs, Department of Environment and Lifestyle, Hokkaido Government

Kita 3-jo Nishi 6-chome, Chuo-ku, Sapporo, Hokkaido, Japan 060-8588

Phone: 011-231-4111 (Extension 24-406)

Email: kansei.bunka@pref.hokkaido.lg.jp

11th Kita no Manga Taisho Application Form

[Notice] Minors require parental consent to apply.

*Office use only

受付番号： 受付年月日： 令和8年 月 日

Category	<input type="checkbox"/> Comic Category <input type="checkbox"/> Illustration Category		Number of pages (including the cover)	* Only for Comic Category
Title				
Author	Pen Name (Group name)			
	Name (Representative's name)	<small>* In case you are submitting your work as a group, please provide the names of all group members, starting with the name of your representative.</small>		
Work summary <small>* Please provide a summary of your comic or the intention behind your illustration.</small>	<small>*If your work relates to a subject that will be considered for use in PR materials etc., please write the subject.</small>			
Contacts <small>(Please provide a phone number where you can be reached during the day on weekdays (if you are under 18 years of age, please provide the contact information of your parent or guardian).)</small>	〒			Birth Date
	Phone Number			<small>*As of January 1, 2027</small> DD / MM / YYYY
	E-Mail			(Age:)
Occupation or Name of School				
Disclosure of your place of residence and age	Municipality of your residence	Yes / No ✖	Age	Yes / No
	<small>* If you choose "No" for the municipality, the organizer will disclose your place of residence as follows: -residence outside of Japan: name of the country -residence within Japan but outside of Hokkaido: name of the prefecture -residence within Hokkaido: name of the region (subprefecture)</small>			
Use of generative AI	Please confirm the following by checking the boxes below.			
	<input type="checkbox"/> My submitted work did not use generative AI at any stage of the creation process, including the story, composition, artwork, or any other aspect of production. <input type="checkbox"/> I understand that if the use of generative AI is discovered, my submission may be disqualified from consideration, or any award granted may be revoked.			
How did you learn about Kita no Manga Taisho?				

If you are applying for the manga category, please fill out the following fields as well.

Returning of the work	<input type="checkbox"/> Yes <input type="checkbox"/> No	<small>* Enclose an envelope with necessary stamps if you want your work returned. (All works submitted from overseas shall not be returned.)</small>
Provision of your information to comic magazine publishers	If comic magazine publishers related to the selection want the information of your work or yourself, do you agree that your information is shared to them?	<input type="checkbox"/> Yes <input type="checkbox"/> No
Comments from judges	If there are comments from judges including comic artists and publishers of comic magazines, do you want us to let you know the comments? <small>* We will let you know the comments as they are made including harsh ones.</small>	<input type="checkbox"/> Yes <input type="checkbox"/> No